

---

# Conclusions

All participants<sup>1</sup>

Wrong things by: Joerg Jaeckel

<sup>1</sup>The Universe

---

# Axions and Stuff

# Light Shining Through Walls

- Status reports from:

- ALPS
- BMV
- GammeV
- LIPPS
- PVLAS
- OSQAR

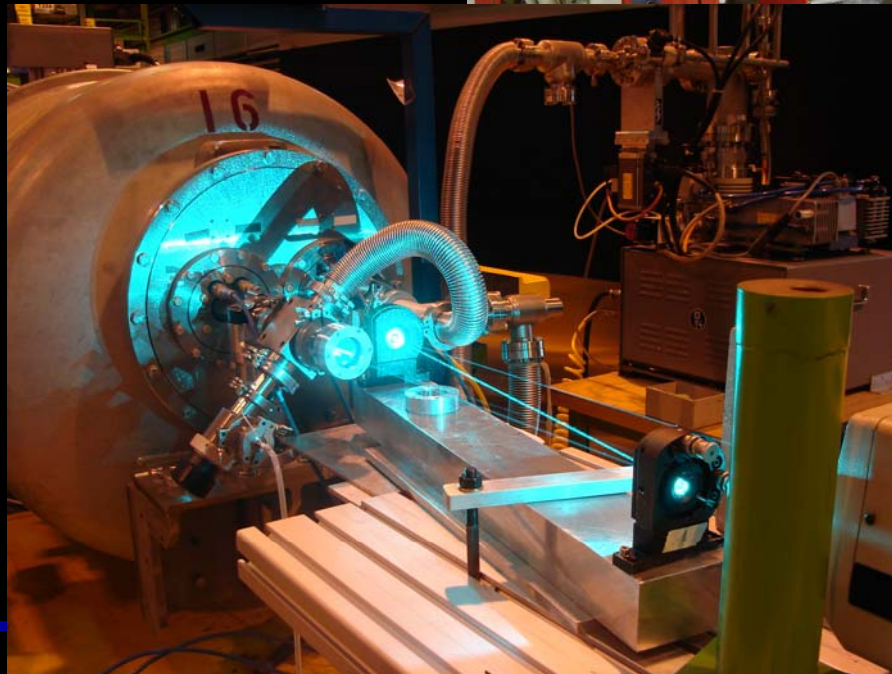
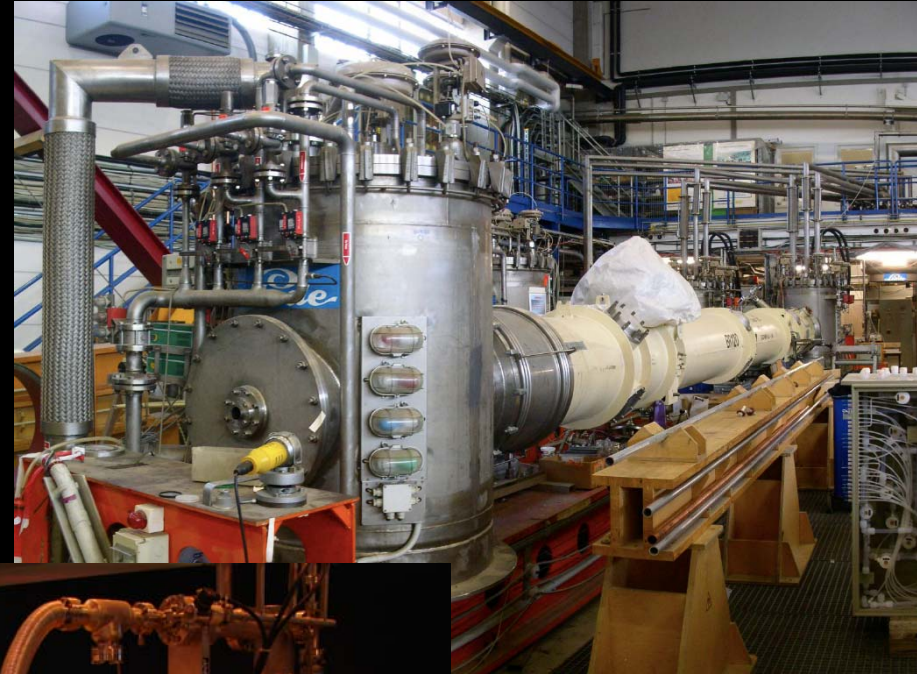
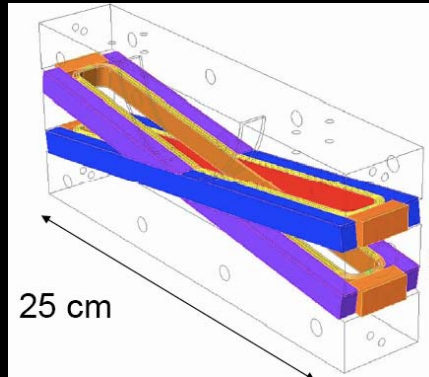

GammeV

# First Results:

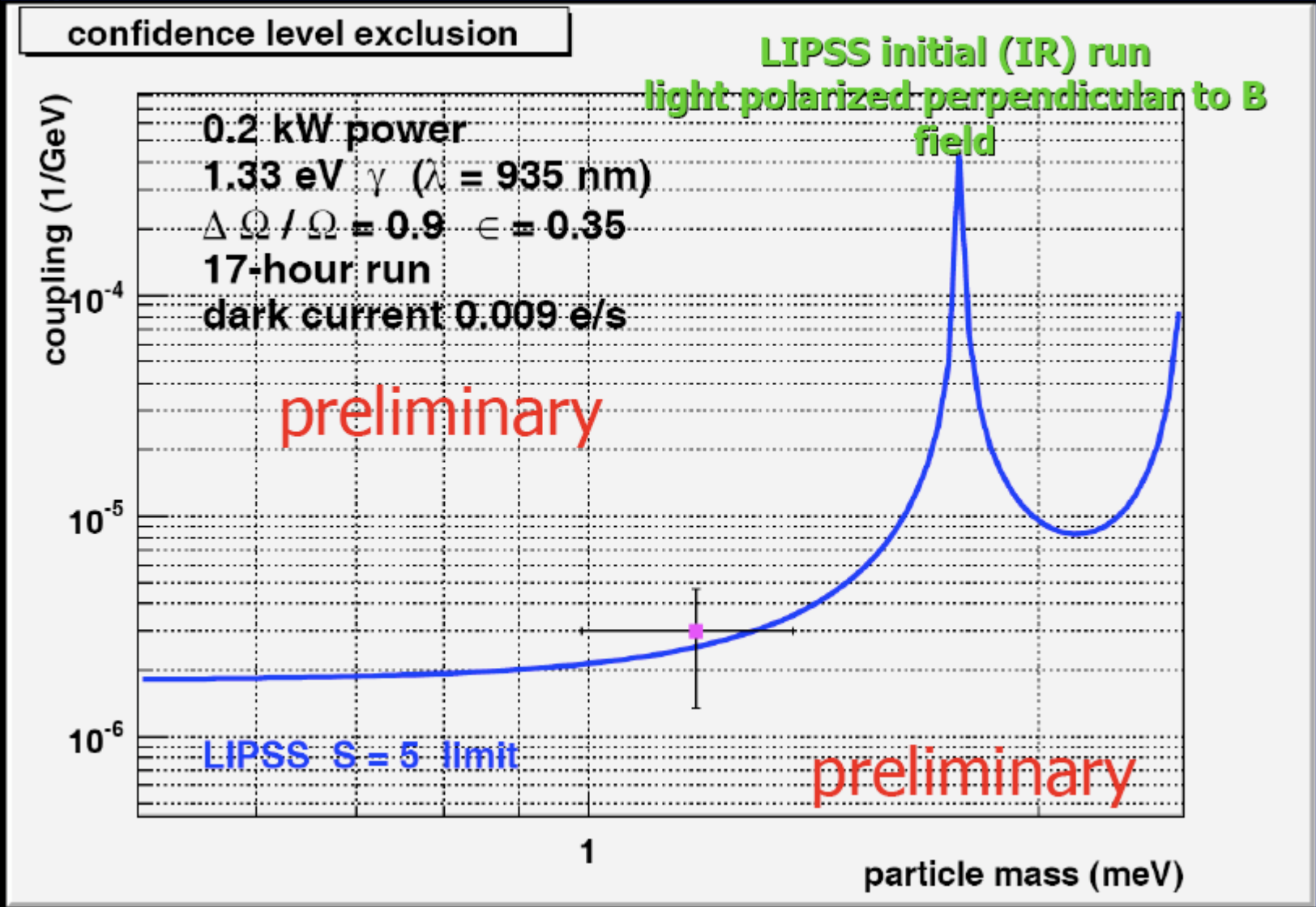

- Several Upgrades

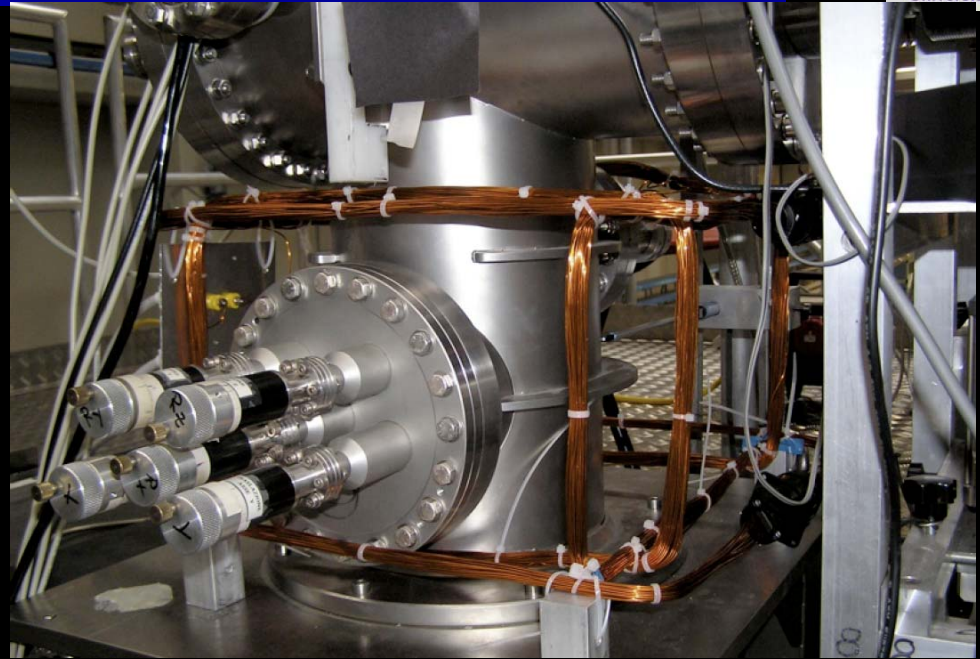

- No signals in rotation and ellipticity at 2.3T
- No rotation at 5T (not enough data on ellipticity)

➡ More sensitivity for the future!

## CAST Phase I/II

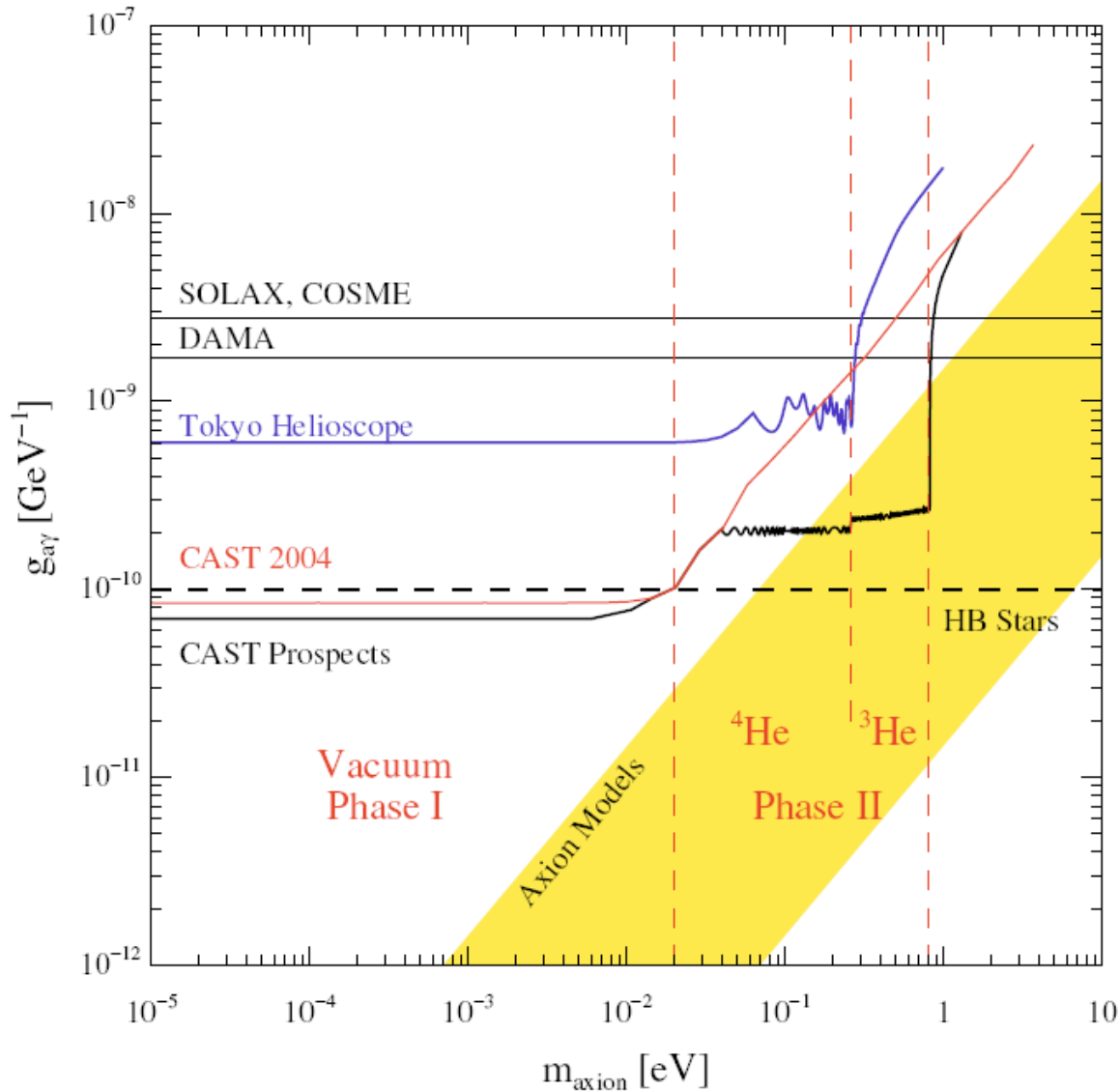



# More CAST: Do not forget about detectors

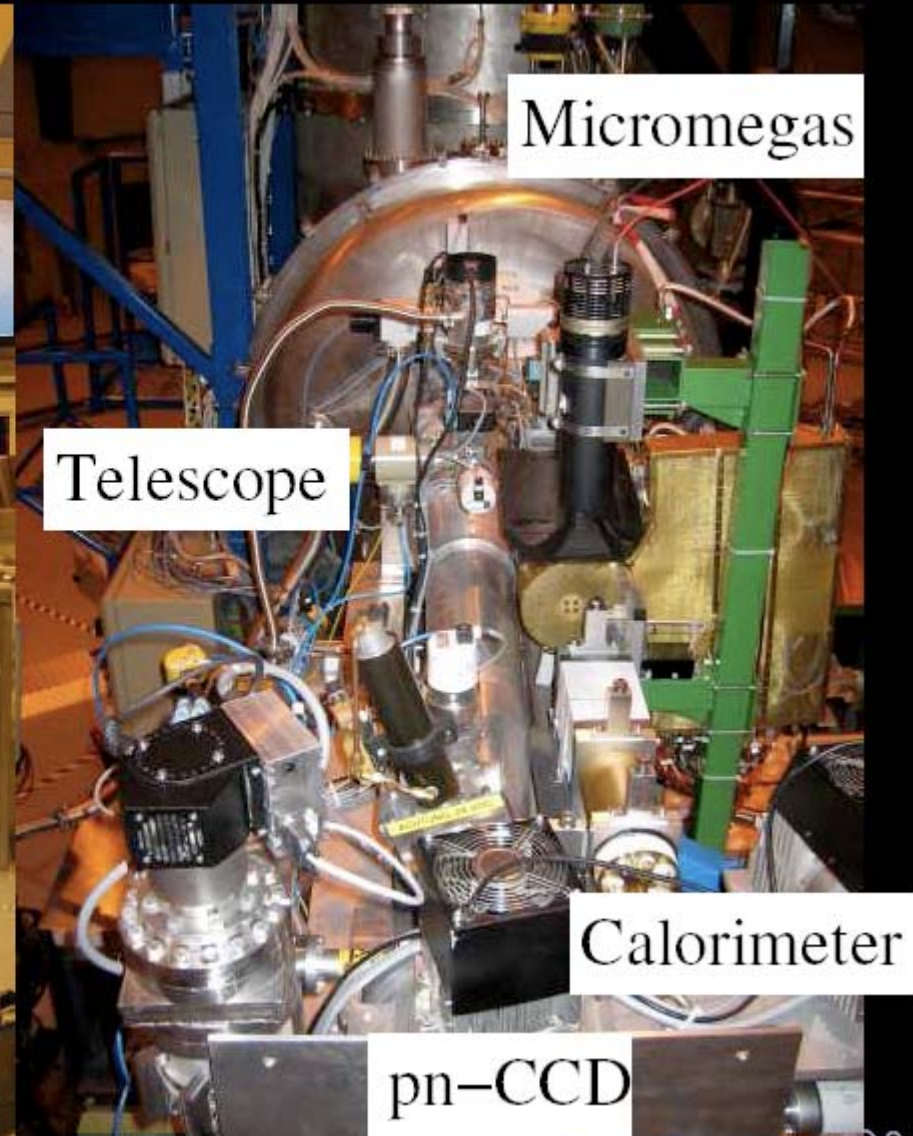
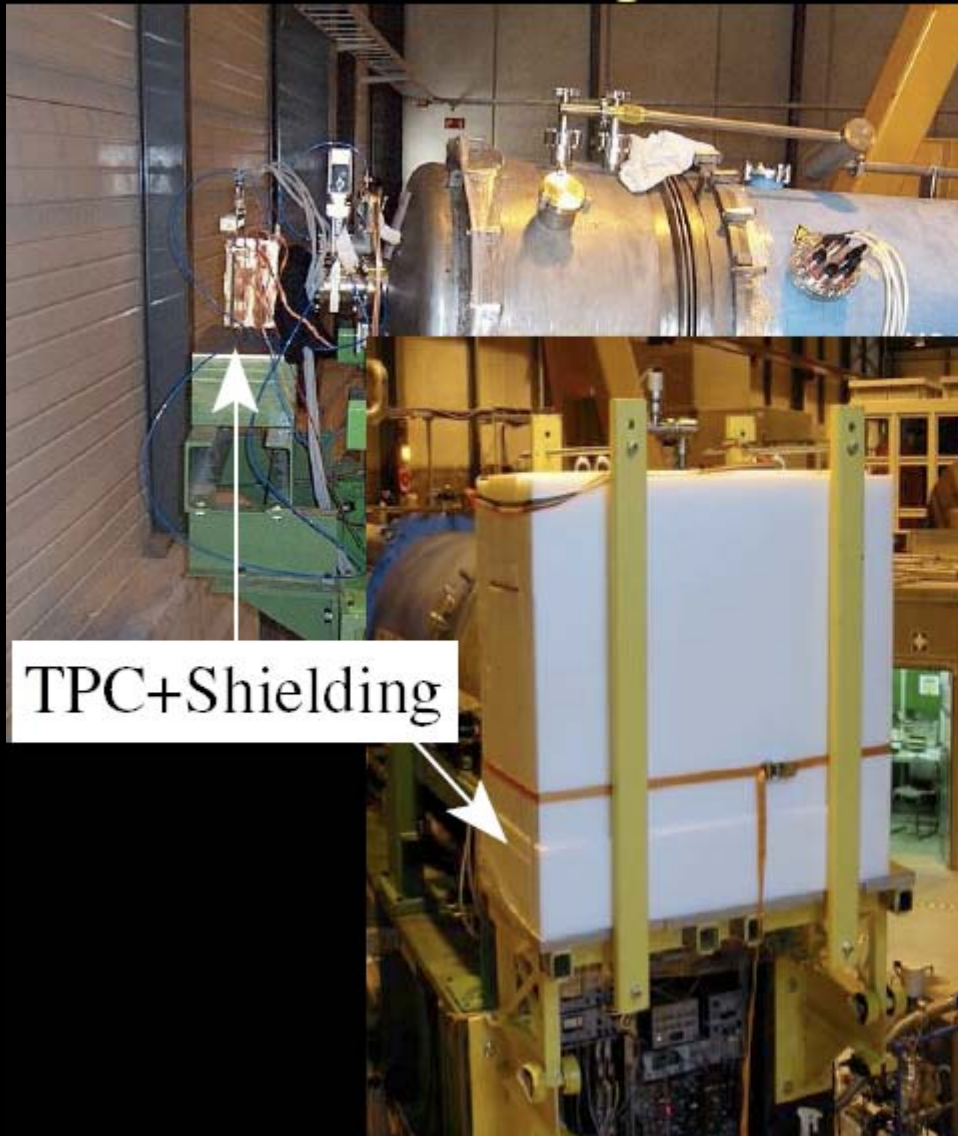

# Low energy frontier

---

- Search for low energy axions from the sun
  - Better theoretical calculations under way
- Corona heating
- Lots of other mysteries...

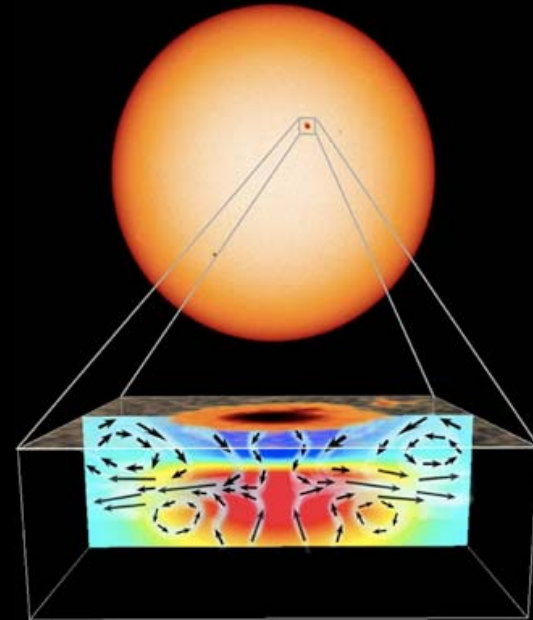



# We shouldn't forget the sun

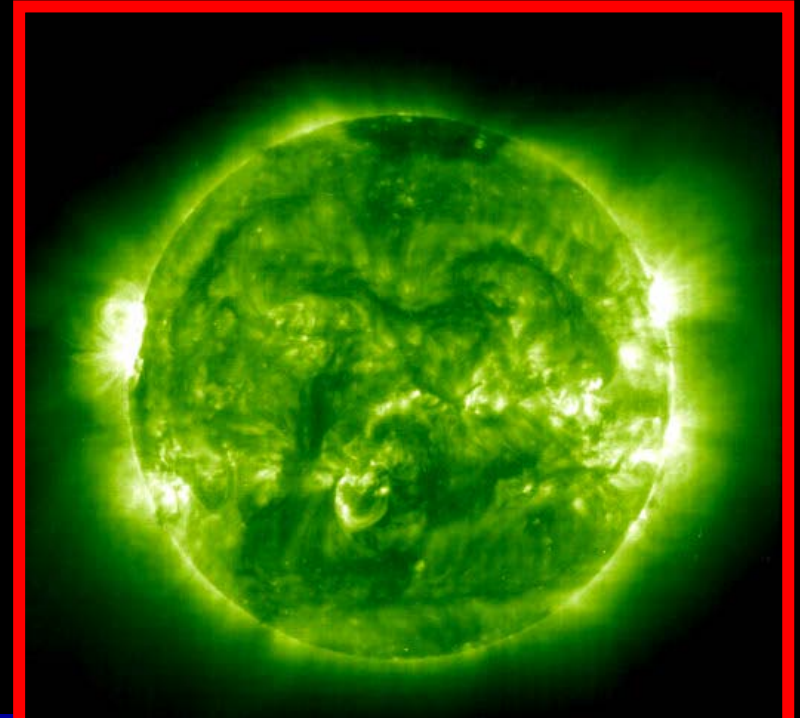
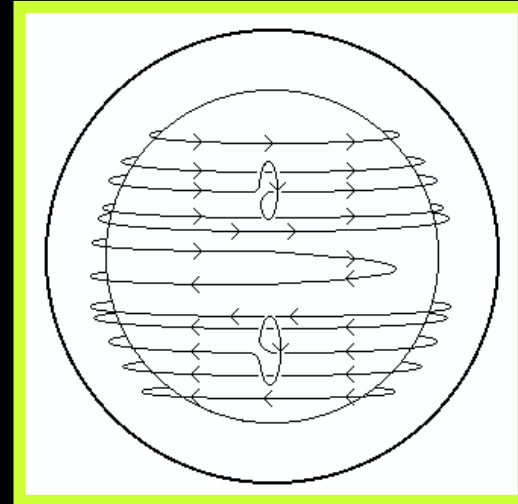
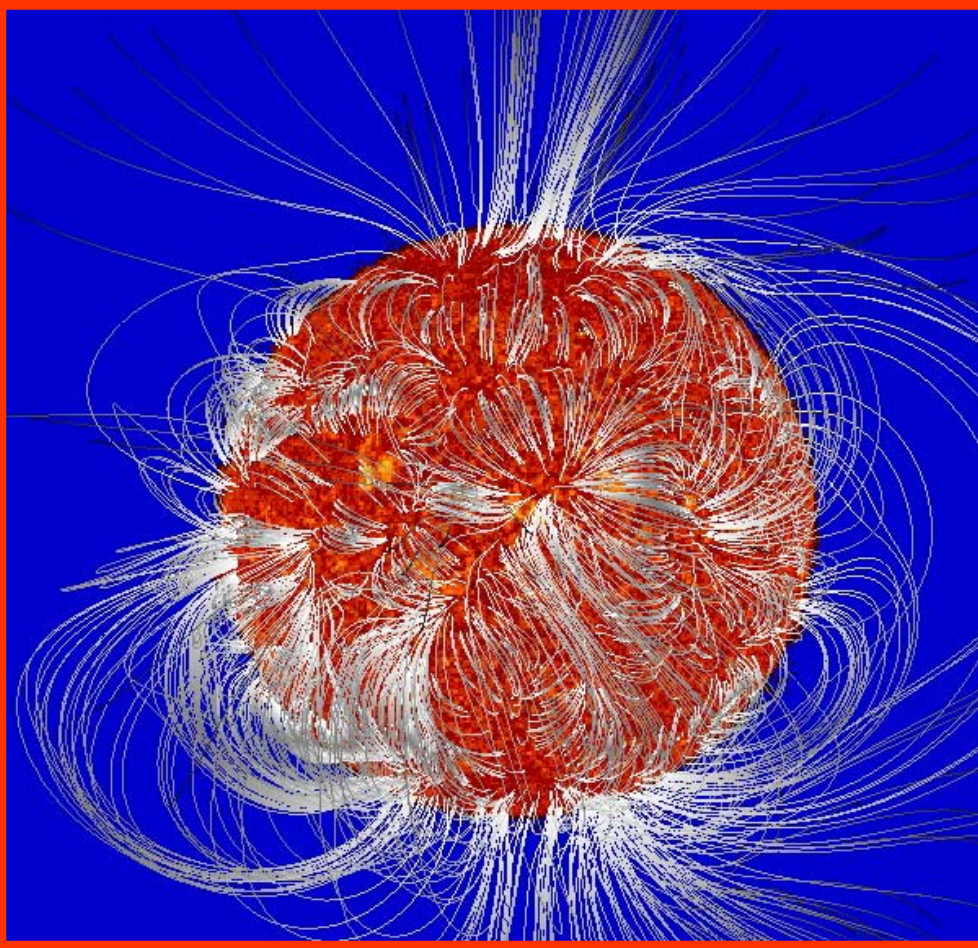

# Axion Dark Matter

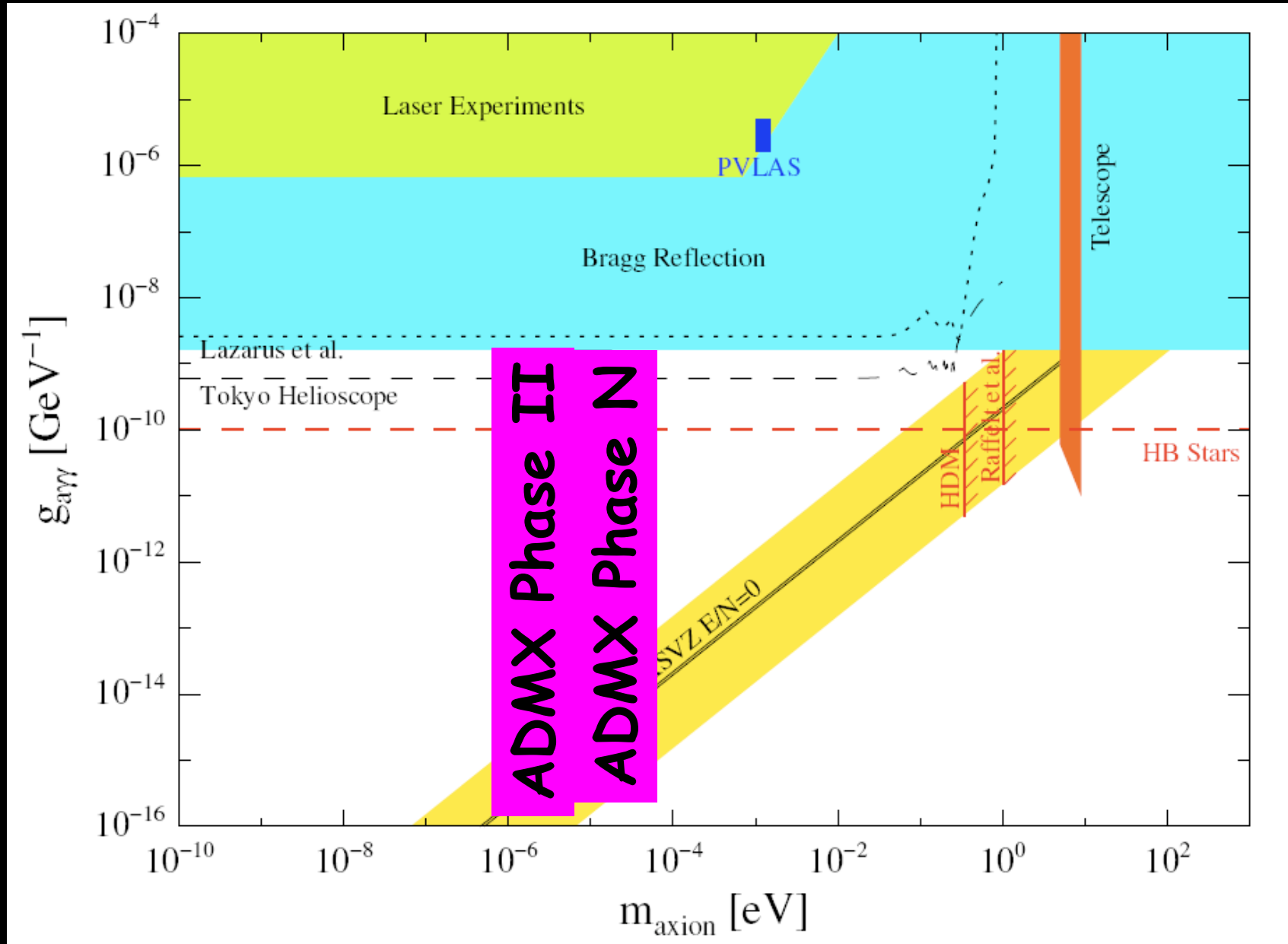

# Microwave detectors

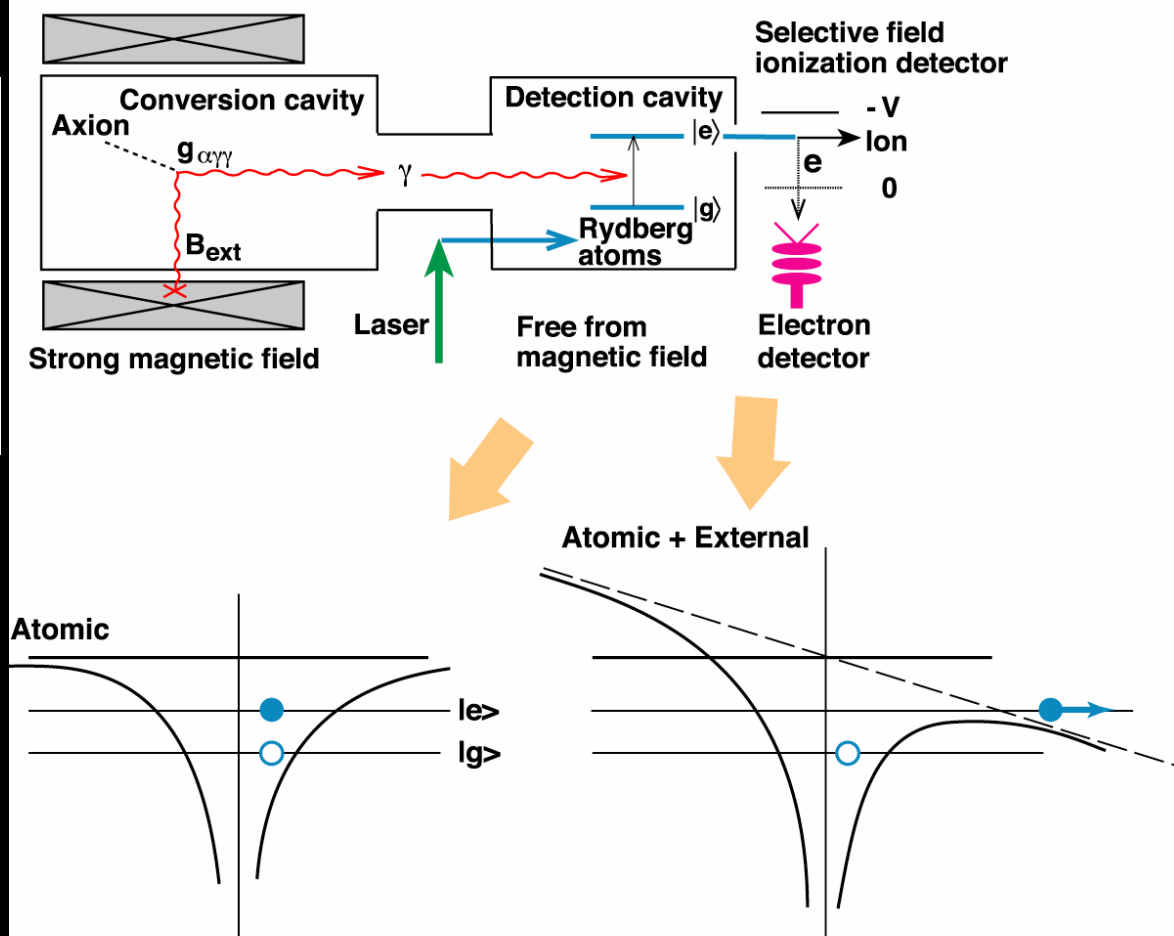
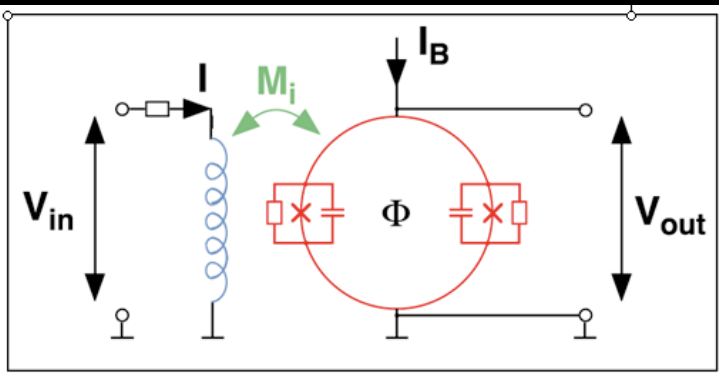

$P \lesssim 10^{-26} \text{ W}$  Detectable!



# Why axions

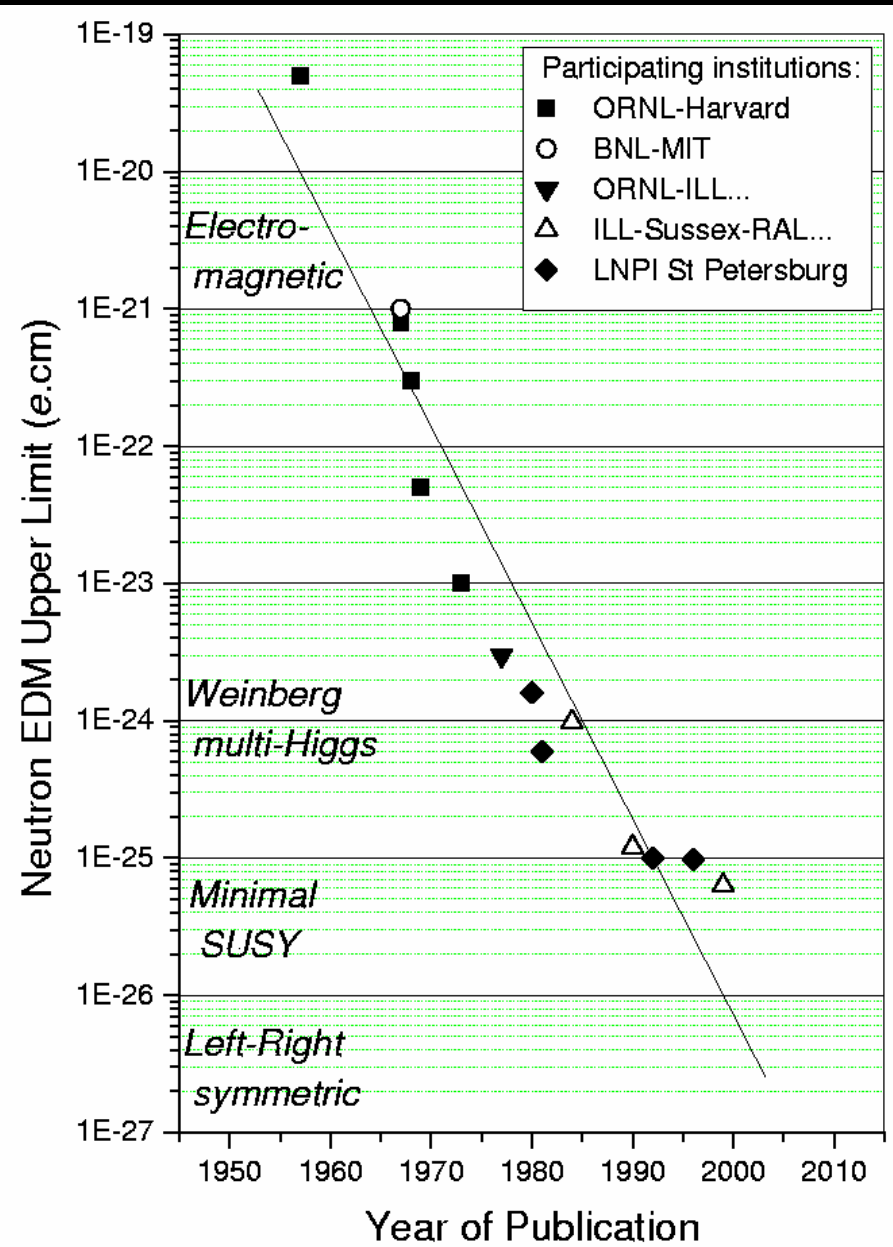
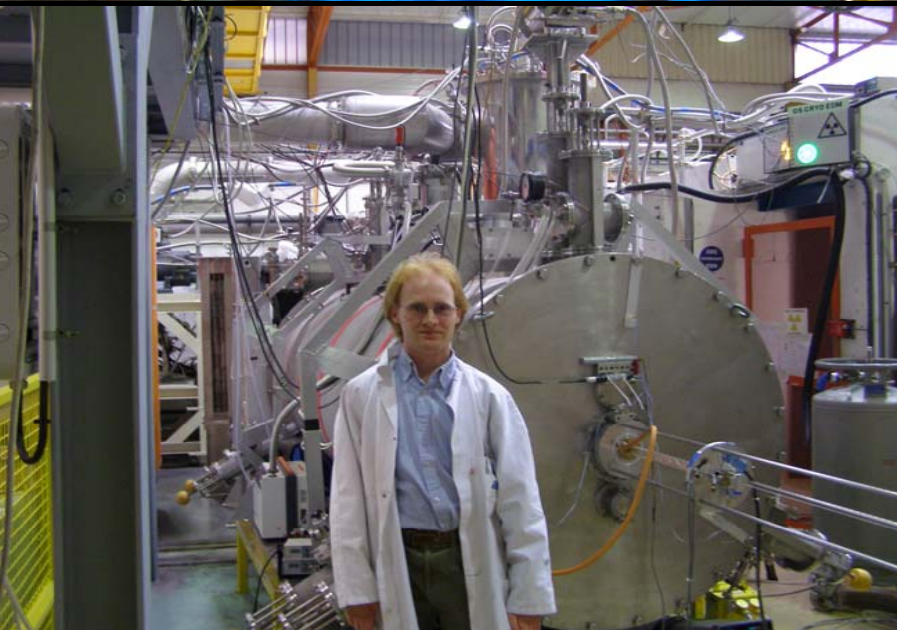
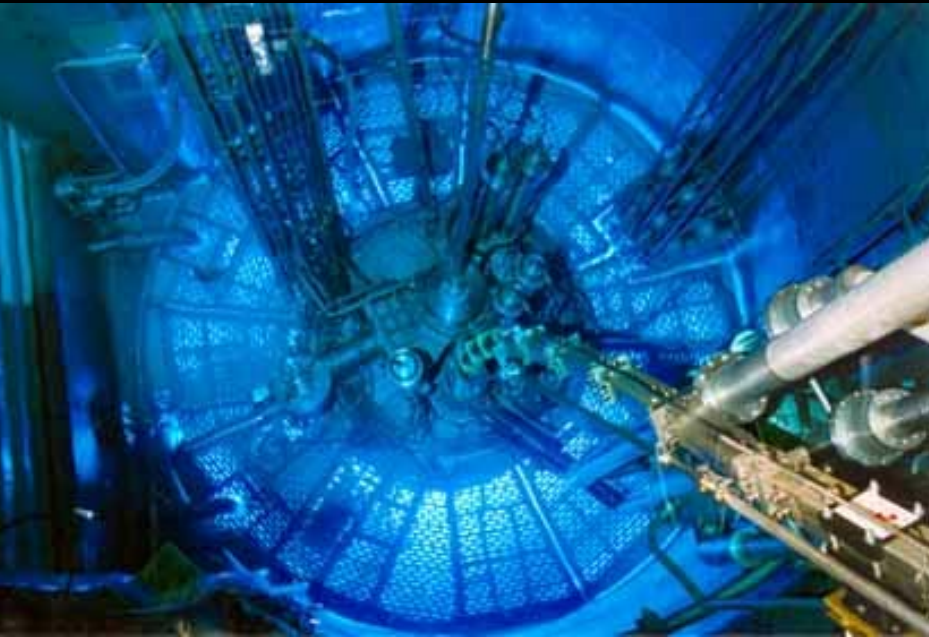



# Theory

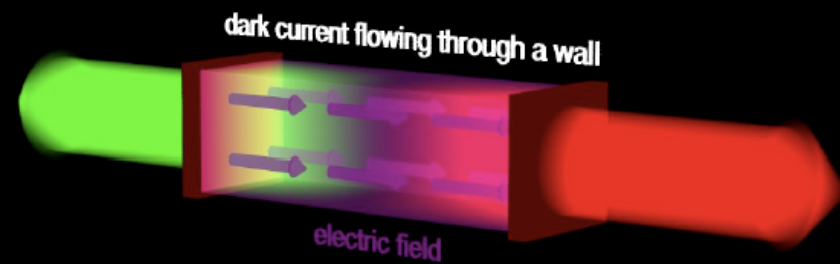
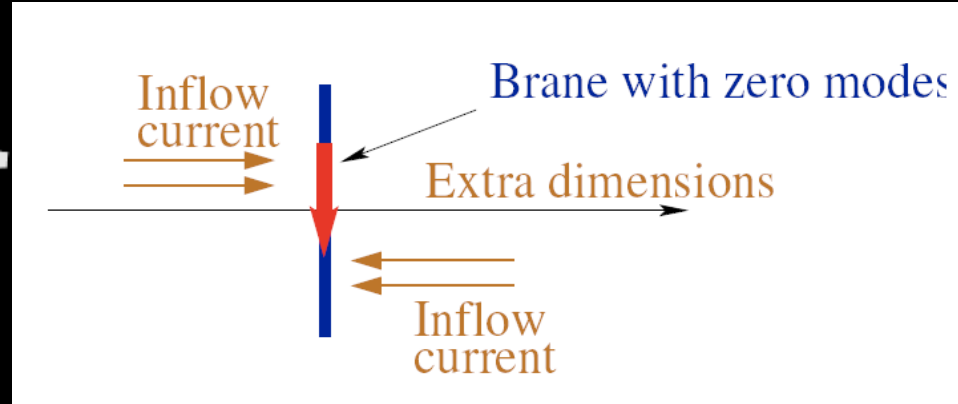
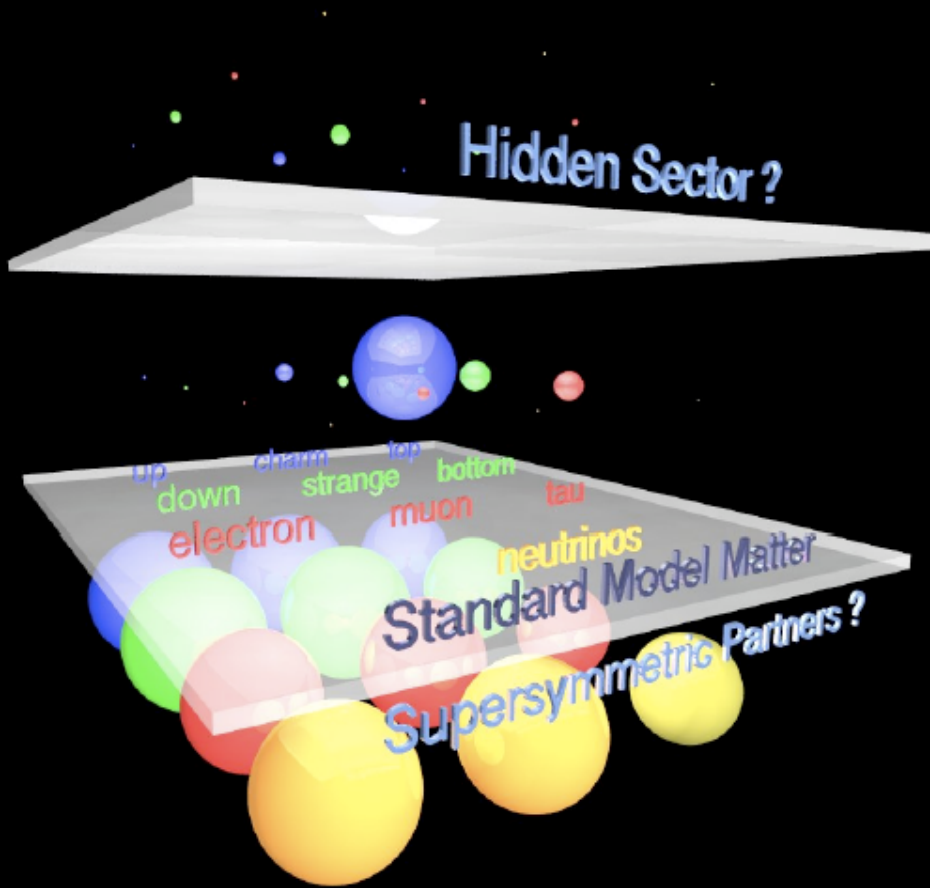

**We can evade astrophysical Bounds!**

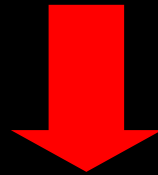

**We need laboratory experiments!**

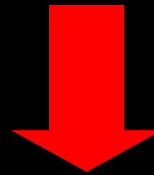

**Find new physics!**

---

**Dark Matter**

# Direct Searches

---

Edelweiss II

CRESST II





# Direct Searches

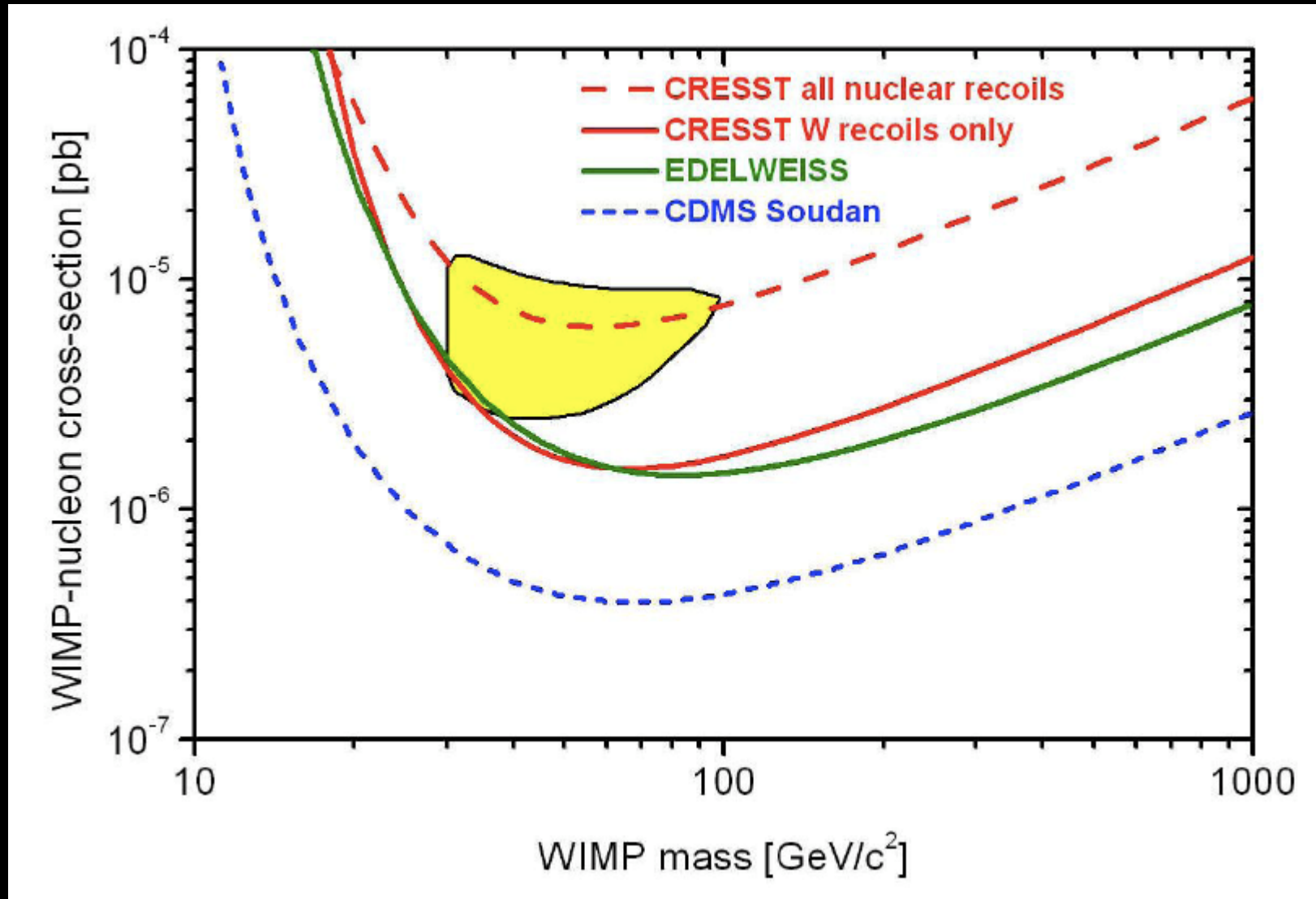

# Learn nuclear physics

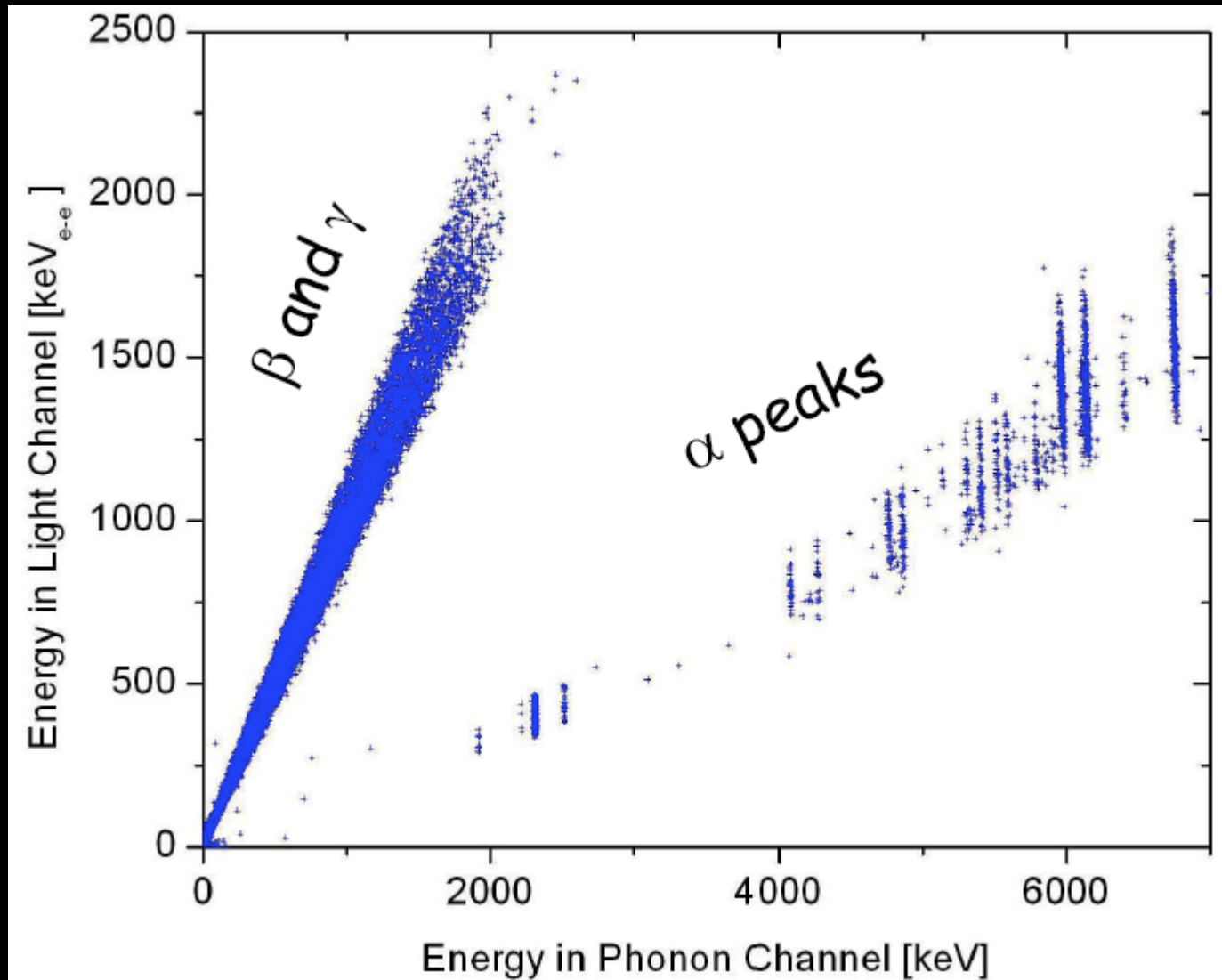

# But also: Searches in the Sky

- WIMP signals in EGRET data
- Flux limits from X-Rays in the Bullet Cluster
- Signs of SSC

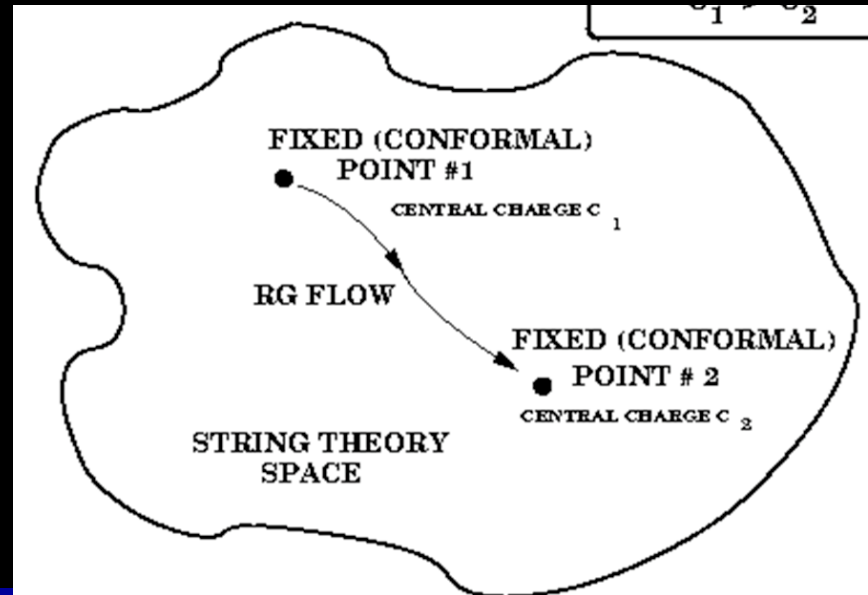
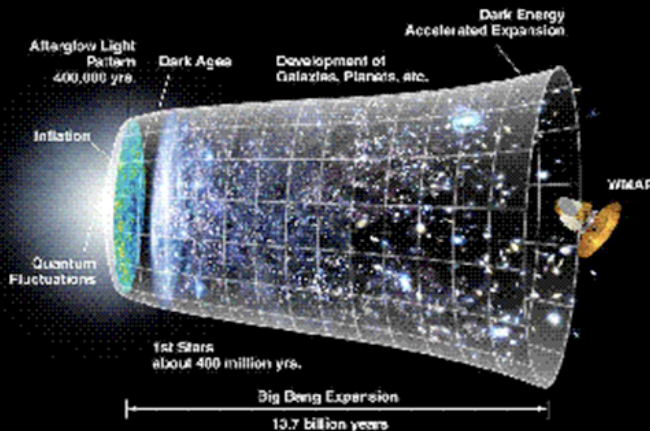

**Last Words**



All those I forgot...



- We are (hopefully) witnessing the birth of a new field...
- Fundamental Physics @ Low energy
- Small scale experiments <<
- Complementary to Accelerators
- Clever Ideas
- More fun!



Thanks to all for a great...

# 3<sup>rd</sup> Joint ILIAS–CERN–DESY Axion–WIMPs Training Workshop

Department of Physics, University of Patras\* / Greece  
19-25 June 2007



\* Patras European Capital of Cultures 2006  
Photo: The longest Bridge over sea in Europe  
in front of the University of Patras

Hope to see you all at the...

# 4th Joint ILIAS–CERN–DESY Axion–WIMPs Training Workshop

Department of Physics, University of Patras\* / Greece

DESY???

2008

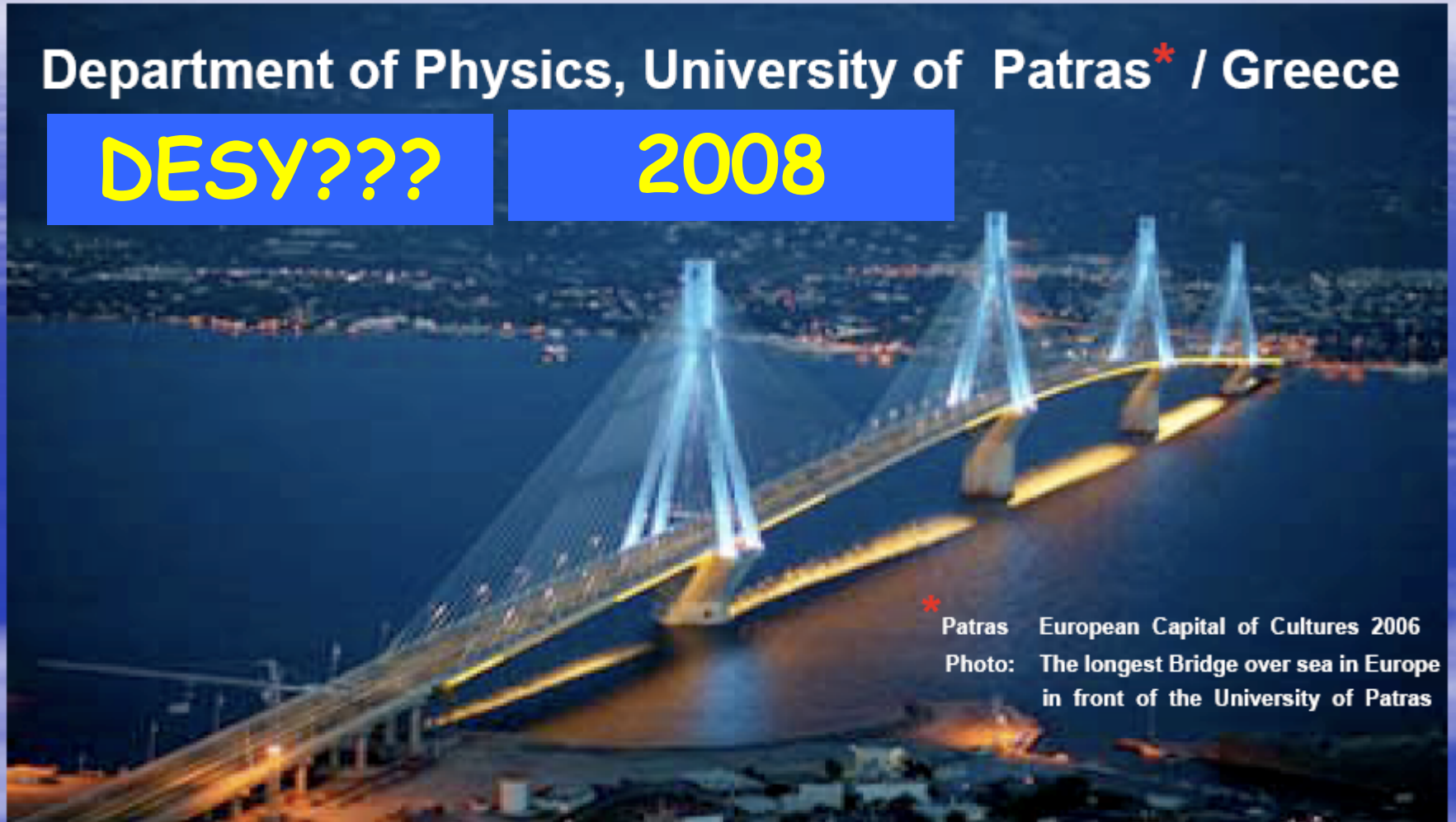

\* Patras European Capital of Cultures 2006  
Photo: The longest Bridge over sea in Europe  
in front of the University of Patras